



Valuweigh
7XXSoftware

Operation Manual and User Guide

Boxer 3

with additional print options

Cardinal Indicator 777 and Windows XP

Revision a12

INDEX

1. Introduction	3
1.1. 777 alphanumeric keypad	3
2. Operating Instructions	4
3. Basic operation mode	5
4. Full printing operation mode	6
5. Totals screen	8
6. Connecting a printer	10
7. Optional EXCEL link	11
8. Connections between 777 indicator and PLC	12
9. Troubleshooting.....	12
10. Connections and cables.....	13
11. Technical information for scale engineers.....	14

1. Introduction

A 777 software application to reduce product damage during filling processes. Containers are lifted closer to conveyors and are gradually lowered to ensure a minimum dropping distance. The software will stop the filling of the containers when the target weight is reached. Proximity switches are used in conjunction with the software to prevent overfilling of containers if the target weight is not reached. The number of containers that have been filled and average weight of the containers is recorded and stored in the 777 RAM. Stored information can be sent to Microsoft Excel via an AWM Excel Link.

1.1. 777 alphanumeric keypad



The 777 keypad has 44 buttons which may be used to input alphanumeric information. Other than the alphanumeric keys there are other buttons such as: **ENTER**, **SPACE**, **SHIFT** and **BACKSPACE** (←).

ENTER - used to confirm end of data input.

SPACE - used to put spaces between characters.

SHIFT - used to change character's case.

BACKSPACE - used to delete previously entered character.

Important Aside: At any point in the program if you wish to return to the previous screen you may press the FNCT button on the right hand side of the indicator screen.

2. Operating Instructions

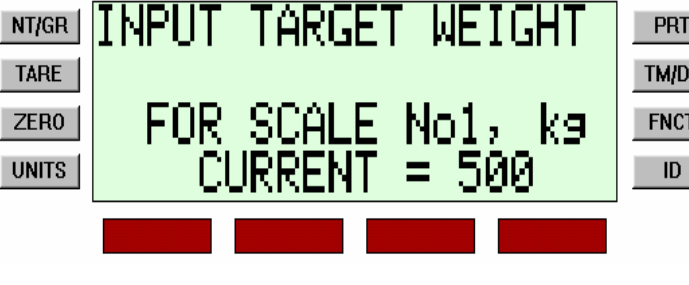
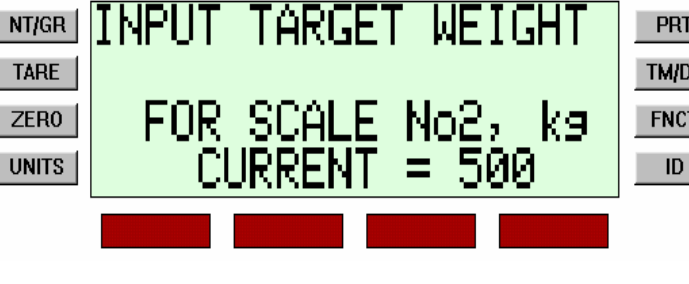
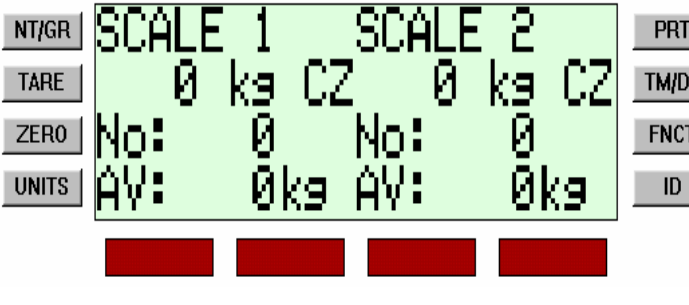
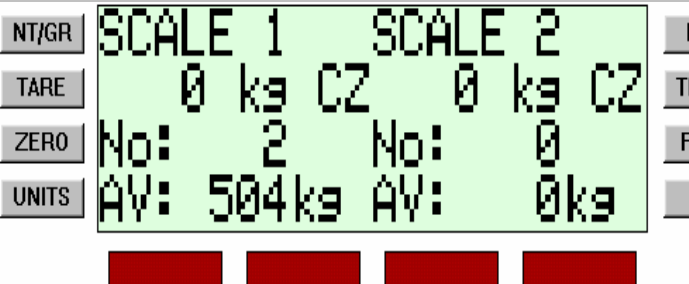
<p>After switching on the Cardinal 777 indicator the display will show</p>	 <p>The screenshot shows a green LCD display with the following text: SCALE 1 SCALE 2, 0 kg CZ 0 kg CZ, No: 0 No: 0, AV: 0kg AV: 0kg. To the left of the display are four buttons: NT/GR, TARE, ZERO, and UNITS. To the right are four buttons: PRT, TM/DT, FNCT, and ID. Below the display are four red rectangular indicators.</p>
<p>To set the target weights press the UNITS button. The display now shows:</p>	 <p>The screenshot shows the display with the text: INPUT TARGET WEIGHT, FOR SCALE No1, kg, CURRENT = 500. The buttons and indicators are the same as in the previous screenshot.</p>
<p>Enter the target weight for scale 1 via the number keys on the 777 keypad & then press the ENTER key. Display now shows:</p>	 <p>The screenshot shows the display with the text: INPUT TARGET WEIGHT, FOR SCALE No2, kg, CURRENT = 500. The buttons and indicators are the same as in the previous screenshot.</p>
<p>Enter the target weight for scale 2 via the number keys on the 777 keypad & then press the ENTER key. Display now shows:</p>	 <p>The screenshot shows the display with the text: SCALE 1 SCALE 2, 0 kg CZ 0 kg CZ, No: 0 No: 0, AV: 0kg AV: 0kg. The buttons and indicators are the same as in the previous screenshot.</p>
<p>Key in, via the keypad, the No. Of the scale to be re-zeroed & then press the ENTER button. Display now shows:</p>	 <p>The screenshot shows the display with the text: SCALE 1 SCALE 2, 0 kg CZ 0 kg CZ, No: 2 No: 0, AV: 504kg AV: 0kg. The buttons and indicators are the same as in the previous screenshot.</p>

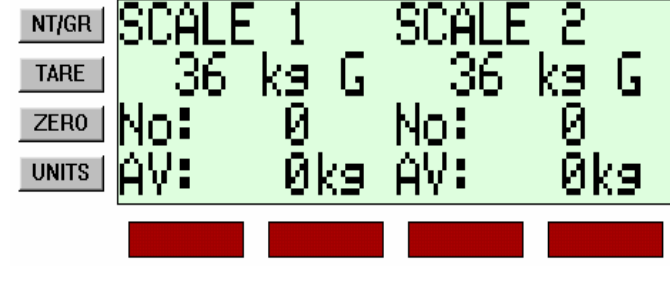
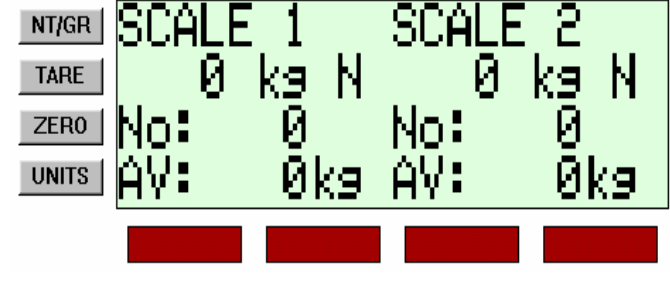
<p>Place the empty box/container, to be filled, on the scales.</p> <p>Display now shows:</p>	
<p>The PLC will send a signal to tare the scales & the 777 display will send a reply.</p> <p>Display now shows:</p>	

3. Basic operation mode

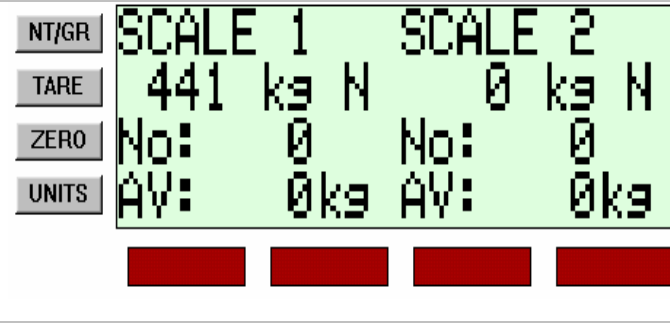
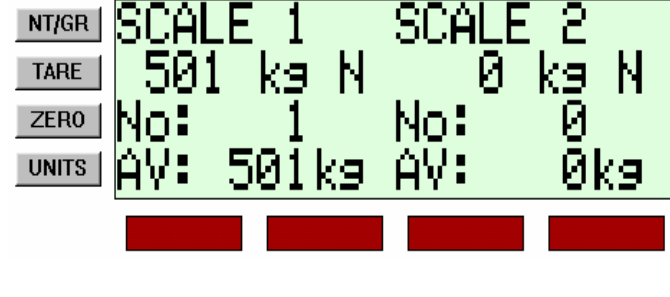
<p>The conveyor will start & the box will begin to fill.</p> <p>Display now shows:</p>	
<p>When the target weight is reached the conveyor will stop.</p> <p>Display now shows:</p>	

The bottom 2 lines of the display show the amount of boxes filled & the average weight for each scale.

4. Full printing operation mode

The user will switch on the machine then press the id button, he will input his customers name then crop type, the user may then reset the accumulator, print a header then start to use the machine, at any point during the day the user may decide to print a customer report to check progress or to show a finished total, also, at any point during the day the user may wish to print end of day report, the figures printed here are running totals for the day regardless of customer or how many times the accumulator has been reset, this is so the user can eventually build up a picture of how conditions, number of staff etc, effect the amount of work he can do in a day.

Press ID button at main screen:

1. Display prompts – CUSTOMER NAME (current name appears below this, type new name over this or press enter to use)
2. Display prompts – CROP TYPE (current crop type appears below this; type new crop type or press enter to use)
3. Display prompts – PRINT HEADER (YES or NO)
If no then move to 4.

If yes the header below is printed

Customer – xxxxxxxxxxxx

Crop – xxxxxxxxxxxx

Date Time Box G/kg N/kg

4. Display prompts – PRINT CUSTOMER REPORT (hit YES or NO)

If no then move to 5.

If yes then print

CUSTOMER – xxxxxxxxxxxx

CROP – xxxxxxxxxxxx

DATE –

TIME -

TOTAL BOXES FILLED – (sum of scale 1 and scale 2)

TOTAL GROSS kg – (sum of scale 1 and scale 2)

TOTAL NETT kg - (sum of scale 1 and scale 2)

AVERAGE WEIGHT PER BOX –

5. Display prompts – clear accumulator (hit YES or NO)

If no then jump to 6.

If yes then clear accumulator for scale 1 and scale 2

After printing the print header (3) the customer will start filling boxes

At each full box the date, time, box number, gross weight and net weight will be automatically printed.

25/01/05	13.04	001	2012	1997
25/01/05	13.10	002	2010	1997
25/01/05	13.24	003	2009	1997
25/01/05	13.28	004	2012	1997
25/01/05	13.32	005	2015	1997
25/01/05	13.51	006	2022	1997

So on the printer it would look like this

CUSTOMER – xxxxxxxxxxxx

CROP – xxxxxxxxxxxx

DATE	TIME	BOX	G/kg	N/kg
25/01/05	13.04	001	2012	1997
25/01/05	13.10	002	2010	1997
25/01/05	13.24	003	2009	1997
25/01/05	13.28	004	2012	1997
25/01/05	13.32	005	2015	1997
25/01/05	13.51	006	2022	1997

6. Display prompts – PRINT END OF DAY REPORT

if no then jump to 7

if yes then program will print an end of day report.

DATE ...

TIME...
 NUMBER OF BOXES FILLED ON THAT DAY ...
 TOTAL GROSS WEIGHT ON THAT DAY...
 TOTAL NETT WEIGHT ON THAT DAY...
 AVERAGE WEIGHT PER BOX ON THAT DAY...

All the information for the end of day report is regardless of customer, or how many times the accumulator has been reset just pure totals for that day,

7. Display prompts – RESET DAY TOTALS (YES/NO).

if no then just jump to main menu

if yes then clear day totals and jump to main menu

5. Totals screen

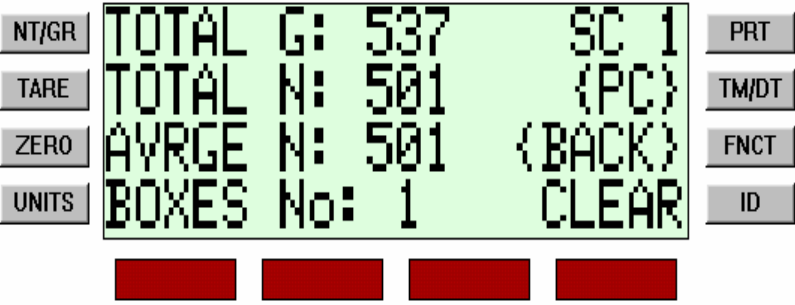
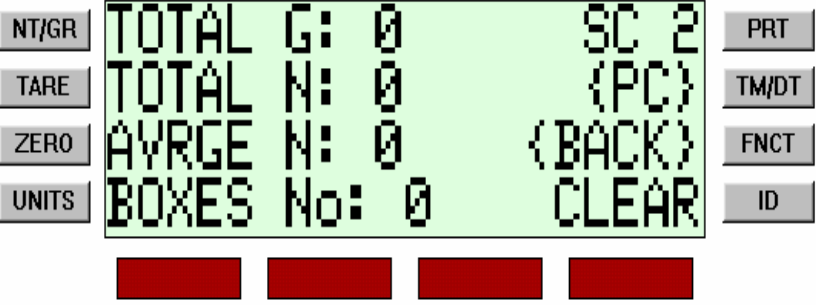
<p>Press the PRINT button or T button on the keypad of the 777 to view the accumulated totals. Display now shows:</p> <p>This is the accumulated Gross, Net & Average weights as well as the total number of boxes filled for scale 1.</p>	
<p>To view the totals for scale 2 press the No. 2 button. (You can toggle between scale 1 & scale 2 by pressing the No. 1 & No. 2 buttons on the 777 keypad.) Display now shows:</p>	

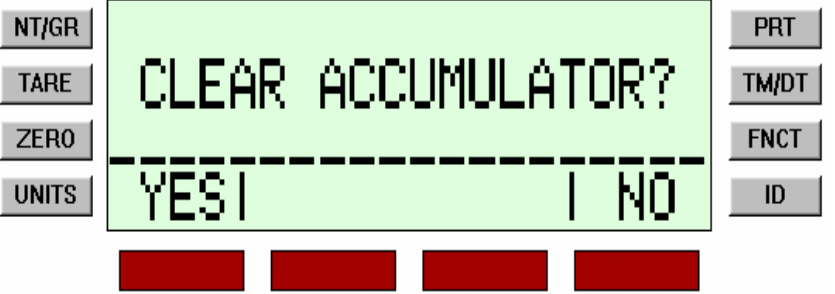
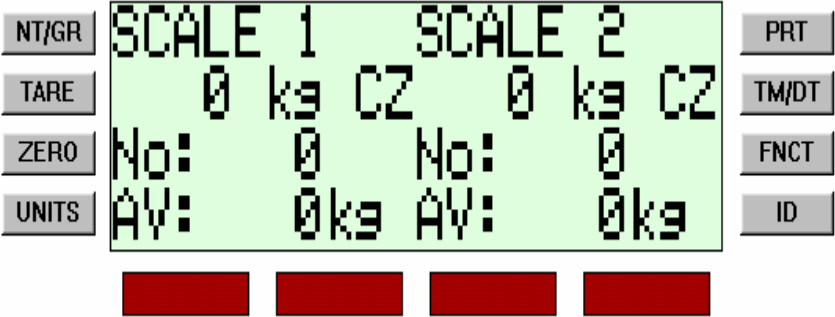
<p>To clear <u>all</u> the Totals press the red button under CLEAR. Display now shows:</p>	
<p>Press the red button under YES & the totals will be cleared. Display now shows:</p>	

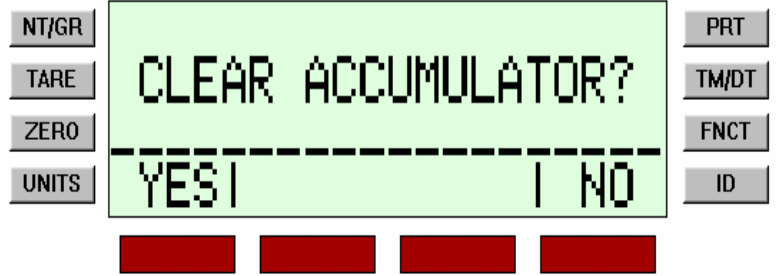
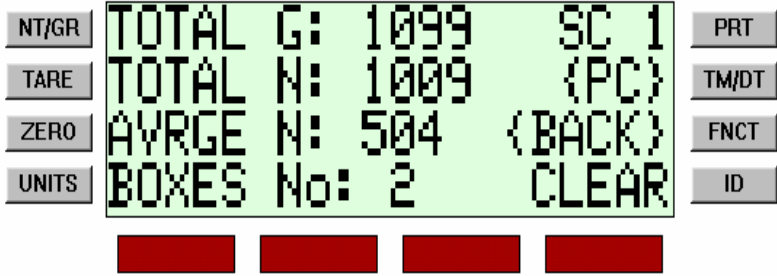
<p>If you <u>do not</u> want to clear the totals then press the red button under the NO.</p>	
<p>Display now shows:</p> <p>To return back to the main operating screen then press the FNCT button.</p>	

Display now shows:	NT/GR	SCALE 1	SCALE 2	PRT
	TARE	0 kg CZ	0 kg CZ	TM/DT
	ZERO	No: 2	No: 0	FNCT
	UNITS	AV: 504kg	AV: 0kg	ID

Check the target weights are correct & you are now ready to start again.

6. Connecting a printer

If you require the Totals to be printed out then you will need to connect a standard serial printer lead to COM1 on the indicator. Connect the other end to the Dot matrix printer & make sure it is configured to 9600 Baud, 8 Data bits, Parity none & stop bits 1.

Press the T on the keyboard or press the PRT button & the display will show	NT/GR	TOTAL G: 1088	SC 1	PRT
	TARE	TOTAL N: 1008	(PC)	TM/DT
	ZERO	AVRGE N: 504	(BACK)	FNCT
	UNITS	BOXES No: 2	CLEAR	ID

If you press the PRT button again then as long as the printer is connected & working you will have the Totals printed out :	Data I/O Simulator	
	14:03	23-10-2003
	SCALE 1	
	TOTAL GROSS:	1088
	TOTAL NET:	1008
	BOXES NUMBER:	2
	AVRGE NET:	504
	AVRGE GROSS:	544
	SCALE 2	
	TOTAL GROSS:	0
	TOTAL NET:	0
	BOXES NUMBER:	0
AVRGE NET:	0	
AVRGE GROSS:	0	

The display now returns to the main operating screen.

7. Optional EXCEL link

You can have the option of sending the Data (stored accumulated totals) to a P.C.

You will need to purchase the AWM Excel PC software.

This will allow you to have the information put into an Excel spread sheet.

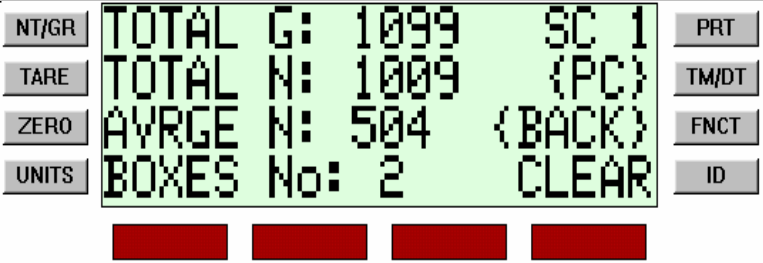
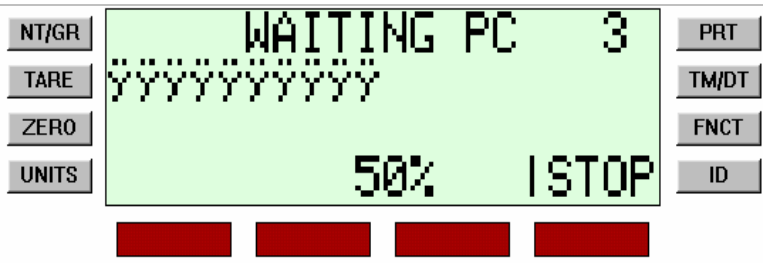
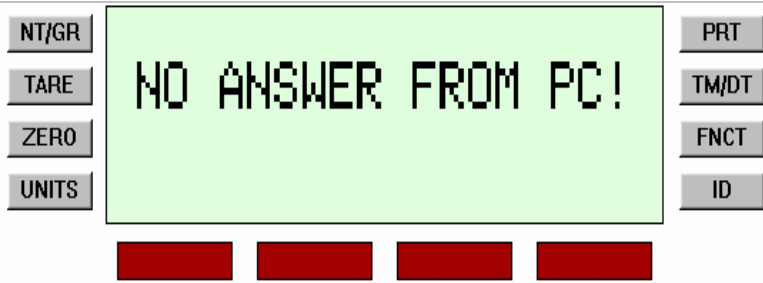
<p>From the display shown in right column you would press the {PC} TM/DT button.</p>	
<p>When you press the (PC) TM/DT button the display will show:</p>	
<p>If the 777 does not get a response from the computer the Data will not be transferred. Display now shows:</p> <p>Then the 777 will return to the main screen.</p>	

If the Data was successfully transferred then the totals are cleared & the 777 briefly shows Data transfer okay.

8. Connections between 777 indicator and PLC

Signals from 777 indicator to PLC:

Tare of scale 1 completed – **relay 1**
Tare of scale 2 completed – **relay 2**
Box 1 target weight reached – **relay 3**
Box 2 target weight reached – **relay 4**

Signals from PLC to 777 indicator:

Tare Scale 1 – **External input 1**
Tare Scale 2 – **External input 2**
Box 1 completed – **External input 3**
Box 2 completed – **External input 4**

9. Troubleshooting

This section covers any problems that may arise when using the system.

- The indicator needs to see zero weight to register a change of weighing object
- The weight is more than zero and less than 20 intervals of the calibration of the 788 indicator. The weight may be too small for the system to register it as a valid weight to be printed
- Platform was unstable and in motion when the button was pressed
- The weight was not in the normal operation range, i.e. it was below zero or the platform was over capacity
- COM port settings of the printer on the 788 are different from the actual printer connection.

10. Connections and cables

The cable that should be used to connect the external device to the 777 indicator has a 9 pin female connector on both sides.

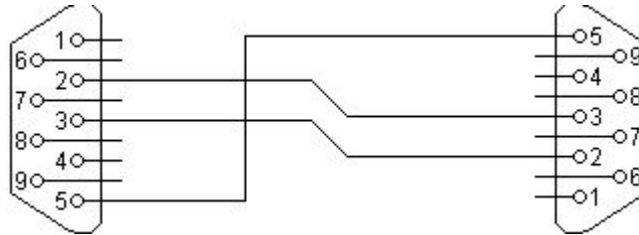

Download cable 9 pin female 777 to 9 pin female PC

However, some PC models use a COM port, which may have 25-pin connector.

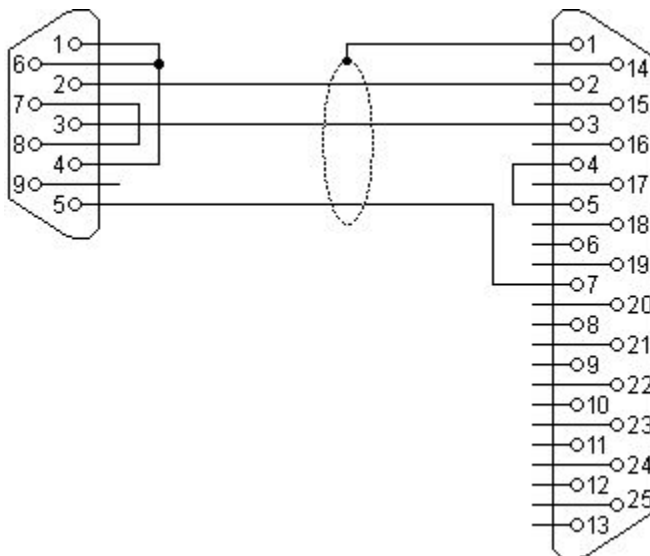

Download cable 9 pin female 788 to 25 pin female PC

11. Technical information for scale engineers

In some cases there is a chance that the hardware port from the PC or the 777 is damaged, or has internal problems. Please be sure that the port is physically working before requesting any software changes.

The easiest way to check both ports is to load the software into the 777 indicator from the PC via a download cable. If the download is successful then there is a bi-directional connection between the PC and the 777 indicator and all communications should work as expected.



**Unit 17/18 Mercers Road, Chapel Pond Hill, Bury St. Edmunds,
Suffolk, IP32 7HX**

Tel: 01284 701222 Fax: 01284 703559