

Display ETW

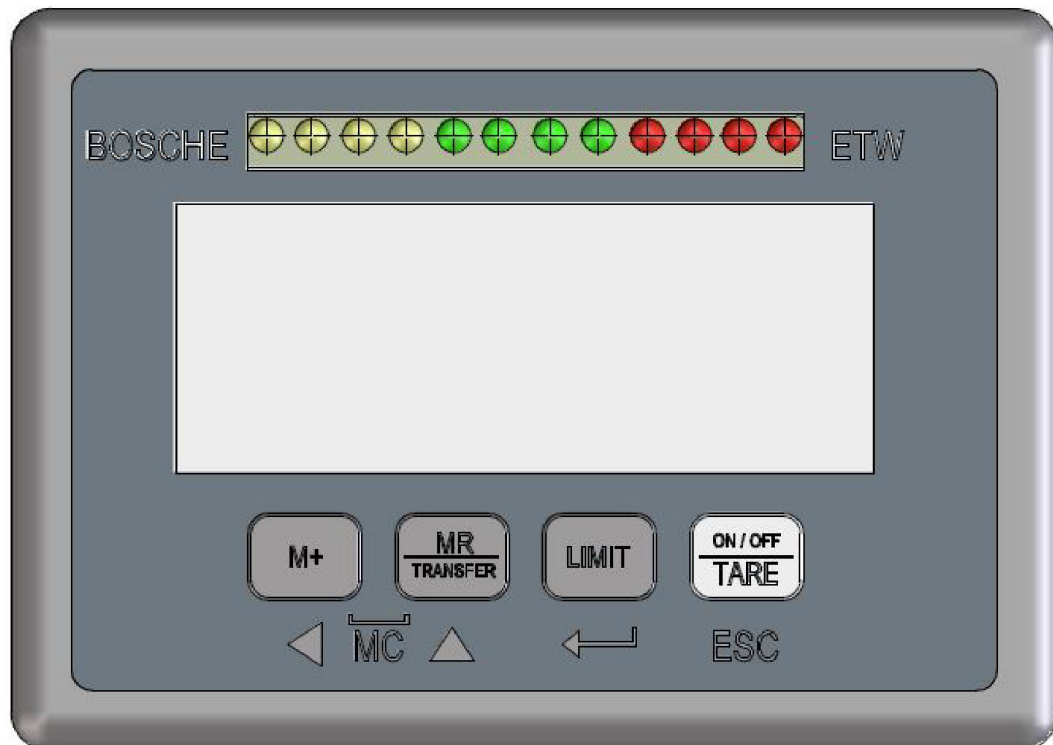

Operating manual - Translation of the original - (keep for future use)

Version 2.4

Status: 2026-03-13

Foreword

These operating instructions provide you with detailed information about the Display ETW.

These instructions contain safety instructions to guarantee safe use.

The manufacturer strives to improve their products on an ongoing basis. They reserve the right to carry out any and all modifications and improvements that they consider to be necessary. However, this means that there is no obligation to carry out retrospective modifications in this connection.



Danger

Before using the Display ETW, you must have read and understood the operating instructions and the safety regulations that they contain.



Note

Errors and omissions in the documentation reserved. If necessary, please inform Bosche GmbH & Co. KG of any errors in the documentation. We would also be grateful for any suggestions for improvements that you may have.

The manufacturer's contact data is listed on the reverse of the title page. If you have any queries or problems, please contact the manufacturer without delay.



Note

Have your serial number to hand when contacting Bosche GmbH & Co. KG.

Table of contents

1 Safety	4
1.1 For your safety	4
1.1.1 General	4
1.1.2 Safety symbols in this manual	5
1.1.3 Safety symbol on the display	5
1.2 Intended use	5
1.3 Obligations of the owner/user	6
1.4 Obligations of the operator	6
1.5 Description of the dangers	6
1.5.1 Danger of injury	6
1.5.2 Danger of damage	6
1.6 Liability and warranty	6
2 Description	7
2.1 Layout	7
2.2 Display	8
2.2.1 Display overview	9
2.2.2 Legend for the weighing value display	10
2.3 Keyboard overview	11
3 Transport, commissioning/start-up and tests/inspections	12
3.1 Control	12
3.2 Packaging and disposal	12
3.3 Regular inspections/checks	12
3.4 Testing equipment monitoring	12
3.5 Extraordinary inspections	13
3.6 Repair work	13
3.7 Use other than the intended	13
3.8 Commissioning / start-up	14
3.9 Installation	15
3.10 Charging the rechargeable battery	16
3.11 Safety information for handling rechargeable batteries	17
4 Operation	19
4.1 Switching on and off	19
4.1.1 Switching on	19
4.1.2 Switching off	19
4.2 Weighing process	20
4.3 Control weighing	20
4.3.1 Switching on and off the three-colour signal light	20
4.3.2 Setting the limit	20
4.4 Different memories	22
4.4.1 Short-term sum memory	22
4.4.2 Long-term memory	22
4.5 Automatic switch-off	24
4.6 Reset to zero	24
4.7 Zero tracing	25
5 Settings	26
5.1 Main menu	26
5.1.1 Adjustment with weight	26
5.1.2 Theoretical adjustment	30
5.1.3 Adjustment correction	34
5.1.4 Reset to factory-settings	34
5.1.5 Setting the time and date	36
5.2 Quick selection menu	38
5.2.1 Setting the background lighting	38

6 Troubleshooting 41

- 6.1 In the event of a malfunction 41
- 6.2 Error messages of the scales 41
- 6.3 Customer service contact data 41
- 6.4 Information for the contact to the customer service 42

7 Technical data 43

- 7.1 Type plate for a mobile display 43
- 7.2 Technical drawing 43
- 7.3 Technical data 44
- 7.4 Scope of delivery 44

8 Menu overview 45

- 8.1 Navigation in the menu 45
- 8.2 Function menu overview 45
- 8.3 Menu protected by a password 48
- 8.4 Quick selection menu (HLG menu) 52
- 8.5 Menu overview (graphical representation) 55

9 Declaration of Conformity 58

- 9.1 Declaration of Conformity for non-verified scales 58

1 Safety

This chapter warns against possible risks when handling the device. The information for detection of risks contained in this chapter is intended to allow a safe and correct operation.



It is important to read and adhere to this operating manual and particularly this chapter prior to operating this device.

1.1 For your safety

1.1.1 General

In addition to safety information, the operating manual includes:

- A general product description
- Information about installation and connection of the device
- Instructions to operate the device
- Maintenance and care instructions
- Troubleshooting and remedy instructions
- Technical data

Always keep this operating manual and additional documents for your personnel at hand in the direct vicinity of the device.

Always adhere to all information, notes, instructions and explanations contained in this manual! Avoid accidents caused by incorrect operations! Also adhere strictly to the valid legal regulations in addition to the safety instructions specified in this manual.

Prior to commissioning/start-up read the safety information/instructions and familiarise yourself with dangerous areas.

The device is constructed according to the current state of art and the valid safety regulations. However, there are risks in the event of incorrect operation or non-observance of the safety regulations:

- Danger to limb and life of operators, third parties and animals staying in the vicinity of the device.
- Danger to the device and other assets of the owner/user
- Danger to the efficient operation of the device.

1.1.2 Safety symbols in this manual

The following symbols are used on all important positions in this manual. Particularly observe these notes and treat very carefully.



Danger

This note indicates the danger of injuries and/or danger to life, if specific behaviour rules are not observed.

When this symbol appears in the operating manual, please take all required safety measures.



Attention

This note warns against damage to assets as well as financial disadvantages and responsibility under criminal law (e.g. loss of the warranty, cases of third party risks, etc.).



Note

Important notes and information about efficient, economic and environmental friendly handling are specified here.

1.1.3 Safety symbol on the display



Strictly avoid water splashes

This pictograph is affixed to the display rear.

1.2 Intended use

The Display ETW exclusively serves to display the weight in combination with suitable weighing cells.

Any further use is considered as not in accordance with the intended use. The manufacturer does not assume any liability for resulting damage.

The intended use also includes:

- Observance of all notes, information, instructions contained in the documentation as well as in all manuals supplied by the manufacturer.
- Adherence of the maintenance and service conditions and intervals prescribed by the manufacturer and
- Observance of technical data.

Adhere to the attendant accident prevention regulations as well as other generally approved technical safety rules.



Note

Always specify the serial number of your display for all questions, orders or jobs. This will facilitate the communication with the manufacturer and prevents error during editing your request.

1.3 Obligations of the owner/user

The owner/user obligates himself to only instruct people to work on the device, who:

- Are familiar with the basic rules concerning safety and accident prevention and are trained in the operation of this device and
- have read and understood the operating manual, the safety chapter as well as the warning notes.

1.4 Obligations of the operator

All people instructed to operate the device obligate themselves:

- to always ensure the safety of other people,
- to read the operating manual, the safety chapter and the warning notes and
- to only operate the device when they are familiarised with its functions.

1.5 Description of the dangers

1.5.1 Danger of injury

- Always switch off the device for care and maintenance work.
- Never insert any pointed objects into the electric contacts.
- Do not change the contacts.
- Stop device operation if the device or the connection line is damaged or malfunctions.

1.5.2 Danger of damage

- Only connect the device to suitable weighing cells (see chapter 3.9 "Installation").
- Never use pointed objects to actuate the device keys.

1.6 Liability and warranty

BOSCHE offers a restricted warranty for components, which became faulty due to strain or material faults. The warranty starts with the date of delivery. BOSCHE retains the right to repair or replace components. Repair work executed during the warranty period will not extend the period of warranty. The warranty becomes null and void:

- In the event of incorrect use / use other than the intended use or incorrect installation
- Incorrect electric connection
- Use of an incorrect or non-licensed analogue / digital converter
- Non-observance of the specifications in the operating manual
- Conversion, modification or opening of the device
- Unintentional or mechanical damage and damage caused by media, liquids, natural wear.

2 Description

2.1 Layout

The Display ETW is a control system and display used to operate an animal scales and to determine the weight of animals. The weighing results can be saved or transmitted.

An integrated three-colour signal light optically supports product weighing

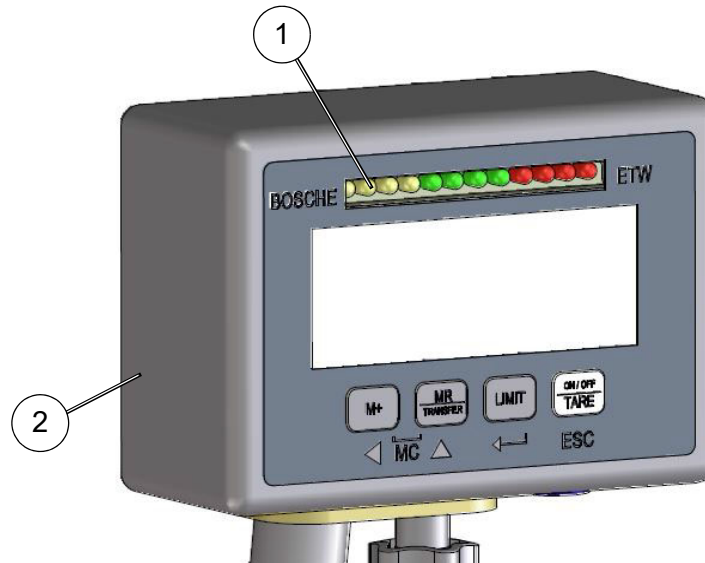

Item	Designation
1	Integrated three-colour signal light (red: Weight too high, green: Admissible weight, yellow: Weight too low)
2	Housing

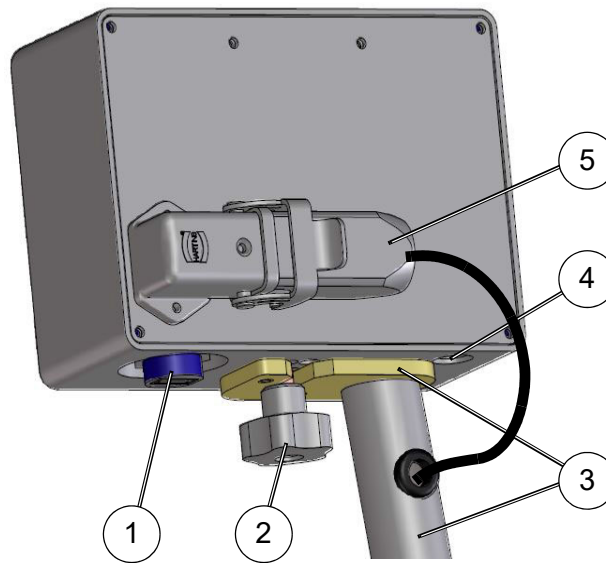





Item	Designation
1	USB connection
2	Fastening for the holder including plate (3)
3	Holder including plate
4	Loading socket
5	Connector with locking for the weighing cell

2.2 Display

The displays of the individual animal scales (ETW) series offers all advantages of quick and accurate weighing. The keyboard is water-proof and the LCD displays are equipped with background lighting as a standard. All displays have a zero function, a three-colour signal light and a sum memory, which allows saving of individual weighing processes and invoking them as a total sum.

2.2.1 Display overview



	Acoustic signal for check weighing is active.	PEAK	Peak function is active
	Stability indicator lights up when a weight is stable.	HOLD	Hold function active - "freezing" of the stable weight value.
	Unstable value	TARE	Weighing with tare value.
	100 % - 40 %: Battery symbol off 40 % - 20 %: Battery symbol flashes slowly. 20 % - 0 %: Battery symbol flashes rapidly (Display turns off). When the power supply is used, the battery symbol remains permanently on.	PRE	Manual tare weighing (Pretara)
Σ	Total of the summed weights.	B	Gross weighing (german)
kg	Active weight unit: [kg, g, t, lb]	G	Gross weighing (english)
N	Newton	Net	Net weighing is displayed.
pcs	Counting mode	→0←	Zero message
%	Percentage weighing	Auto	Automatic summation is active.
*	Data are transferred to a USB stick.	W1 W2	Active weighing range (W2 at multiple range scales).
	Animal weighing function	10x	10-fold resolution possible

2.2.2 Legend for the weighing value display





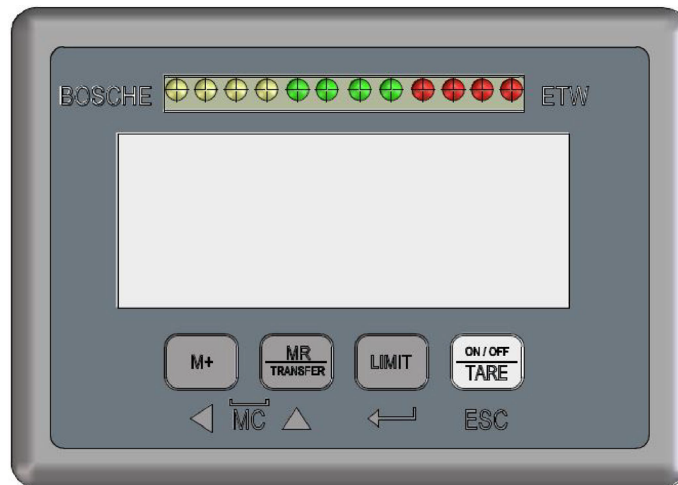

A	B	C	D	E	F	G	H	I	J	K	L	M
A	b	c	d	E	F	G	h	i	J	K	L	M

N	O	P	Q	R	S	T	U	V	W	X	Y	Z
n	o	P	q	r	s	t	u	v	W	X	y	Z

0	1	2	3	4	5	6	7	8	9
0	1	2	3	4	5	6	7	8	9

2.3 Keyboard overview



Key	User level	Function level
	The current weight on the scales is saved.	The activated number during parameter value setting or setting of other functions can be displaced to the left. 
	When a USB stick is connected, the data are transmitted to the stick. For this purpose, press the "MR_TRANSFER" key for two seconds. The sum of the saved individual weighing processes and the resulting total weight are displayed. To delete individual weighing results simultaneously press the keys "M+" and "MR_TRANSFER" (MC).	The activated number during parameter value setting or setting of other functions can be increased. 
	If the keys "LIMIT" and "ON/OFF_TARE" are actuated simultaneously, the saving process is cancelled.	Apply the input during parameter value setting or setting of other functions.  ENTER
	Used to switch on and off the display device. For switch off, press the key "ON/OFF_TARE" for two seconds, OFF appears in the display.	Leaving the function level. ESC

3 Transport, commissioning/start-up and tests/inspections

3.1 Control

When the display is delivered, check the packaging, the device and possible accessories for visible damage.

3.2 Packaging and disposal

Keep all parts of the original packaging for a possible return.



Note

Only use the original packaging, if the display is returned.

Prior to the transport, disconnect/fasten all loose/moving parts of the device. Secure the parts against slipping/damage.

Dispose of the packaging and the display according to the national and/or local regulations by law valid on the installation site. Separately dispose of a defective battery according to the national and local regulations on environmental protection and recycling.

Do not treat this product as standard waste. Please dispose of via a waste management company.

3.3 Regular inspections/checks

Check the display for visible damage, prior to each use. Also check electric lines for damage, prior to each use. If defectives can be detected, immediately stop operating and any other work on the display or the electric lines and contact an authorised expert.

3.4 Testing equipment monitoring

Quality assurance requires regular inspections of the technical measuring features of the display in connection with the scales and a possible available test weight. The owner/user can define a suitable interval as well as the scope of these inspections.

3.5 Extraordinary inspections

After special incidents, the display must be additionally inspected visually by an authorised person (even if not within the regular inspection interval).

Inspection criteria

- Correct function of the display.
- Damage to the housing.
- Damage to electric lines and connectors.

If defectives can be detected, immediately stop operating and any other work on the display or the electric lines and contact an authorised expert.

3.6 Repair work

Only the manufacturer or persons instructed by the manufacturer are allowed to carry out repair work on the display.

The electronic components are not completely water-proof and must not come into contact with splash water or being immersed. If the electronic components become wet or visible damage can be detected, stop operating the scales.

If spare parts or accessories are required, please contact your supplier.

3.7 Use other than the intended

- Protect the electronic display unit against humidity. Particular protection is required during cleaning work.
- If small amounts of the goods to be weighed are removed or added, incorrect weighing results might appear caused by the “Stability compensation” integrated in the scales!
- Never modify the design of the display. This can lead to incorrect weighing results, technical safety defects as well as the destruction of the display.
- Only use the display in accordance with the described specifications



Danger

**Never operate the display in potentially explosive atmosphere.
The display is not explosion protected.**

- Only use original spare parts.

**Attention**

The design/construction of the product as well as all regulations (standards, etc.) specified in the operating manual refer to the directives valid in Germany. Only use the product in other countries in accordance with the directives, regulations and laws valid in the country of use.

Only use original spare parts!

3.8 Commissioning / start-up

Keep the device clean and do not expose to an environment influencing the display accuracy.

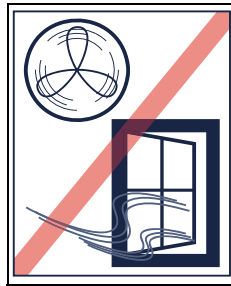

Protect against draught!

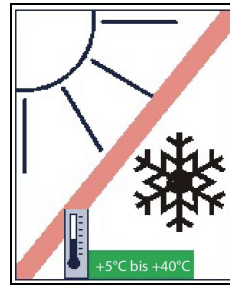

Protect against heat, sun and frost!

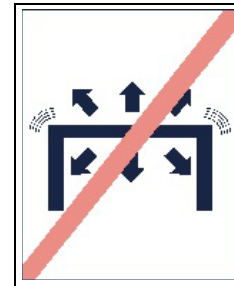

Protect against tilting and vibration!

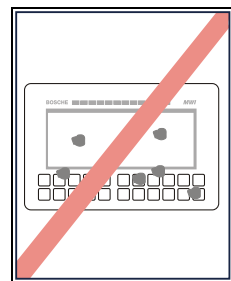

Keep the unit clean

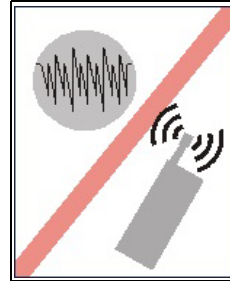

Avoid unstable voltage sources!



Avoid humidity!

Observe the following, prior to commissioning/starting up:

Ensure that the weight on the scales does not exceed the maximum load!

**Note**

Allow a short heat-up time to stabilise the display (approx. 15 minutes).

**Note**

Ensure that a 230 V AC voltage supply is available on the installation site (unless operation with rechargeable batteries is intended).

3.9 Installation

Connection of a 4-wire weighing cell

Square plug

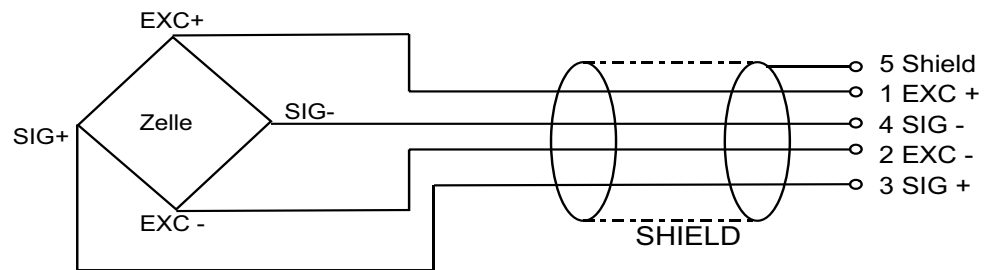

Pin assignment:

1. EXC +
2. EXC -
3. Signal +
4. Signal -

3.10 Charging the rechargeable battery

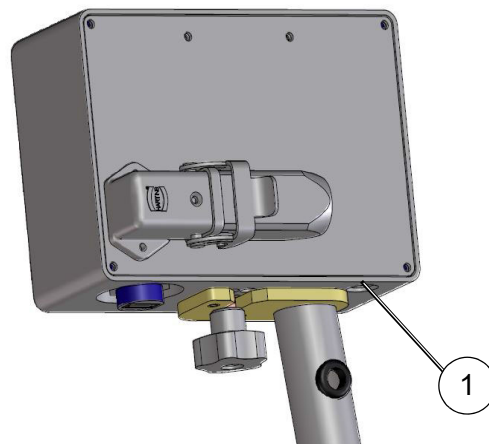

- Connect the mains cable to the loading cable connection (1) and insert the connector in the socket.
 - The charging process automatically starts.
 - The battery symbol lights up on the display as long as the battery is charging.

Complete charging of a completely discharged battery takes approx. 4 hours at 23°C. The charging period depends on the ambient temperature and the charging status of the battery. The charging might take longer if the temperature is lower.

Charge the battery on the day of use or the day before. Batteries are also discharged during storage, even if not used.

The power pack can also be used in other countries. It can be connected to voltage sources with 100 to 240 V alternating current and 50/60 Hz. If necessary, use a common socket adapter for the respective country. Never connect any mobile voltage converters, otherwise, the power pack and the display could be damaged.



Note

The battery is worn, if the voltage decreases quickly after charging. Contact the responsible expert.

3.11 Safety information for handling rechargeable batteries and power cables

Only use batteries, power sources or accessories intended for this use by the manufacturer.

Never use batteries designed or modified by yourself.

Never short-circuit rechargeable batteries, disassemble them or modify them in any manner.

Ensure that the battery does not in contact with heat, soldering material, fire or water.

Ensure that the battery is not inserted opposite to the specified polarity direction (+/-). Do not simultaneously use new and old batteries or different battery types.

Only charge the rechargeable battery within the admissible ambient temperature range. Do not exceed the charging time.

Do not insert any foreign objects made of metal into the electric contacts of the display, accessory parts, connection cables, etc..

Never store batteries in the vicinity of children. Immediately contact a doctor when your child has swallowed up the battery.

Prior to disposing of the rechargeable battery, insulate the contacts with tape to avoid direct contact to objects made of metal. In this manner, you can prevent a fire.

If the battery or the power pack heat up excessively during charging, immediately interrupt the process by disconnecting the connector of the battery charging unit.

Immediately remove the battery when liquid or gel emerges. If the battery changes its colour or shape, disconnect it from the scales or the power pack. Be particularly careful to avoid burning injuries.

Contact with the battery fluid can lead to skin irritations and/or blindness. If emerged fluid comes into contact with eyes, skin or clothing, immediately rinse the area in question thoroughly with water. Subsequently see a doctor.

Never store cables in the vicinity of heat sources. This can deform cables and damage their insulation leading to the danger of electrocution or fire.

Never use the display and the charging unit in the vicinity of highly flammable gas.

Do not disassemble or modify the display.

Do not store the display in moist or dusty environment.

If the scales drops into water or water ingresses the housing, immediately remove the battery.

Never cover the power packs or charging units with cloths or wrap cloths around them. This might result in heat accumulation.

Ensure that the connector is completely inserted in the socket.

Never touch charging and mains cable with wet hands.

Pull the mains cable on the connector out of the socket (not on the cable).

Ensure that power cables are not damaged, cut, kinked or loaded with heavy objects. Never twist or interlace cables. Prior to using cable drums, unwind the cable completely. Do not connect too many connectors to one socket. Do not use any cables with damaged insulation.

Regularly disconnect the connector from the socket and remove any soiling and dust from the connector and the socket environment.

Close the charging socket of the display with the protective cap when no charging unit is connected.

4 Operation

4.1 Switching on and off

4.1.1 Switching on

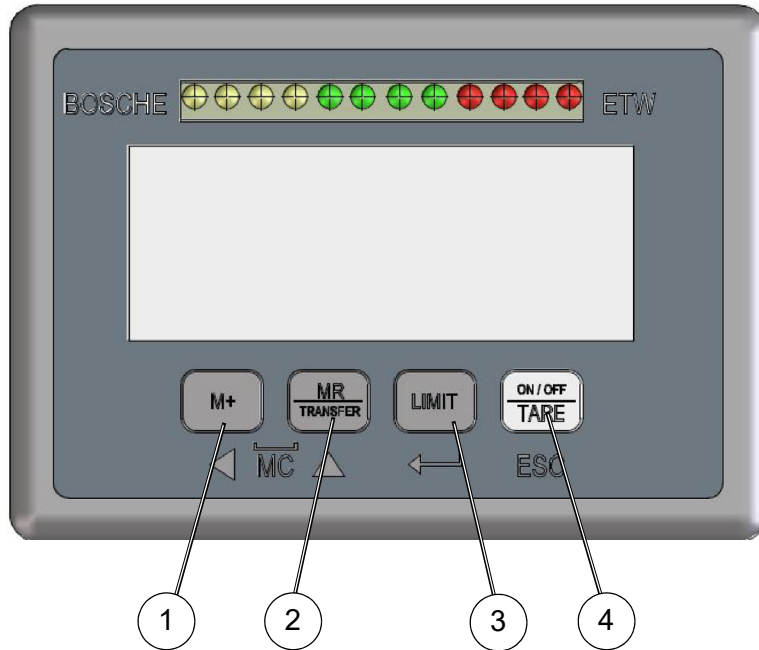

- Press the key (4) “ON/OFF_TARE”.
 - The display is switched on.
 - The software version is displayed.
 - Then a display self test is made and the scales automatically sets to “0.0”.
- The display has an automatic function to reset the scales to zero. If the scales displays small numbers, press the key (4) “ON/OFF_TARE”. Weighing starts at zero.

4.1.2 Switching off

- Press the key (4) “ON/OFF_TARE” for two seconds.
 - “oFF” appears briefly in the display.
 - The display is switched off.

4.2 Weighing process

- Place the goods to be weighed on the weighing plate. For animals: Wrangle the animals into the scales.
 - The stability display appears with stable values 



- If the goods to be weighed are heavier than the set weighing range, "E.OLP" (= overload) appears on the display.



4.3 Control weighing

The control weighing can be used to check the weight of individual animals. The three-colour signal light additionally indicates whether or not the weighed animals are too light or too heavy.

4.3.1 Switching on and off the three-colour signal light

- Press the key (3) "LIMIT" for two seconds.
 - The status of the three-colour signal light briefly appears on the display.
Status "ON": The three-colour signal light is activated.
Status "OFF": The three-colour signal light is deactivated.

4.3.2 Setting the limit

- Briefly press the key (3) "LIMIT".
 - The message (LOW) appears on the display:



- Briefly press the key (3) "LIMIT" again.
 - The display changes over to the value input.

- The RH display flashes.

A digital display showing the number 001070 in a seven-segment font, enclosed in a rectangular border.

- Enter the lower tolerance value. If the weight is higher, the three-colour signal light is lit green. If the weight is lower, the three-colour signal light is lit yellow.
- Press the key (2) <UP> to adjust the value.
- Press the key (1) <LEFT> to go on by one digit to the LH side and adjust the value.
- Actuate the key (3) <ENTER> to confirm the lower tolerance value.

- This message briefly appears in the display:

A digital display showing the word "done" in a seven-segment font, enclosed in a rectangular border.

- The message (HIGH) appears on the display:

A digital display showing the word "HIGH" in a seven-segment font, enclosed in a rectangular border.

- Briefly press the key (3) < ENTER> again.
 - The display changes over to the value input.
- Enter the upper tolerance value. If the weight is higher, the three-colour signal light is lit red.
- Proceed in the same manner as for the "LOW" entry.
 - Then the display automatically switches to weighing mode.

4.4 Different memories

4.4.1 Short-term sum memory

- Press the key (1) “M+” to save the current weight.
 - The current weight is displayed.
 - Ensure that the scales always returns to “0” (zero) (the symbol **→0←** appears on the display) before the next weight can be added to the memory.
- Press the key (2) “MR-TRANSFER” for two seconds.
 - The number and sum of the saved weighing results appear.
 - Then the display automatically switches to weighing mode.
- The sum memory is cleared by simultaneously pressing keys (1) “M+” and (2) “MR_TRANSFER” briefly (1 sec).
 - Once deleted, the weighing results cannot be restored.

4.4.2 Long-term memory

All weighing results are saved in the long-term memory. The long-term memory can be transmitted to a USB stick. Then it is available as .csv file for evaluation on a computer.

- Connect the USB stick.
 - The message “USB In” appears on the display.
 - The star symbol appears on the right of the display, i.e. the USB stick can be used.
- Briefly press the key (2) “MR_TRANSFER”.
 - The data from the long-term memory is transmitted to the USB stick.
- Remove the USB stick and connect it to a PC.
 - The USB stick contains the folder “BOSCHE”.
- Open this folder.
 - The .csv file(s) contain(s) the weighing results of the individual days. All weighing results of one day are in this case (main menu/USB/Single) automatically grouped in one file.
 - The file can be opened with Microsoft Excel or the text editor.

The following data is transmitted:

1st Consecutive number of the weighing process (alibi No.).

2nd Date

3rd Time

4th Gross weight in kg

5th Tare

6th Net

7th Weight unit

Deleting the long-term memory

- Press the key (1) "M+" for two seconds.
 - The message (High-Low-Go-Mode) appears on the display:

The image shows a digital display with the text "H L o G o" in a stylized, segmented font. The characters are arranged in a single line, with "H" and "L" being uppercase and "o", "G", and "o" being lowercase. The display is enclosed in a rectangular border.

- Press the key (2) "MR_TRANSFER".
 - The message (memory) appears on the display:

The image shows a digital display with the text "M E m o r y" in a stylized, segmented font. The characters are arranged in a single line, with "M" and "E" being uppercase and "m", "o", "r", and "y" being lowercase. The display is enclosed in a rectangular border.

- Press the key (3) "LIMIT".
 - The display shows the message (Clear alibi memory):

The image shows a digital display with the text "C L r . A L B" in a stylized, segmented font. The characters are arranged in a single line, with "C", "L", "A", and "B" being uppercase and "r" being lowercase. There is a period after "r". The display is enclosed in a rectangular border.

- Press the key (3) "LIMIT".
 - The display shows the message (Clear No):

The image shows a digital display with the text "C L r . n o" in a stylized, segmented font. The characters are arranged in a single line, with "C", "L", and "n" being lowercase and "o" being lowercase. There is a period after "r". The display is enclosed in a rectangular border.

- Press the key (2) "MR_TRANSFER".
 - The display shows the message (Clear Yes):

The image shows a digital display with the text "C L r . Y E S" in a stylized, segmented font. The characters are arranged in a single line, with "C", "L", and "r" being lowercase and "Y", "E", and "S" being uppercase. There is a period after "r". The display is enclosed in a rectangular border.

- Press the key (3) "LIMIT".
 - The display shows the message (Clear done):



- The long-term memory is deleted.
 - The message "Memory" appears again on the display.
- Press the key (4) "ON/OFF_TARE".
 - The display automatically switches to weighing mode. The weighing process can take place as usual.

4.5 Automatic switch-off

The display has an automatic switch-off function. The time period can be set between 1 and 99 minutes. The automatic switch-off becomes active, if the weight does not change on the platform or weighing bridge during the set time period. The automatic switch-off is deactivated as a standard and must be activated in the quick menu. For an overview and detailed explanations of the quick menu, please refer to the chapter "Quick menu A06-01 - AU off (Automatic switch-off)".

4.6 Reset to zero

The display has an automatic function to reset the scales to zero to compensate for minimum deviations caused by the environment or soiling on the scales. However, it might be possible, that low values appear on the display although the platform is empty. The display can be reset to zero at any time using the key (4) "ON/OFF_TARE" to ensure that the weighing actually starts with zero.

The zero setting range can be selected +/- 0, 2, 4, 10, 20, 50, 100 % of the weighing range.

4.7 Zero tracing

The zero tracing function automatically corrects small deviations of the zero display. The range of the zero tracing can be set between the following values:

Off / 0.25d / 0.5d / 1d / 2d / 3d / 4d (up to max. 1 % of the maximum load)

The zero tracing function must be activated in the menu.

Zero tracing:

- is only active after the switch-on zero setting range.
- is active in both directions, positive and negative.
- operates actively up to the set limit.
- deactivates itself when the set limit is exceeded.
- reactivates itself once the load has been removed.

5 Settings

5.1 Main menu

5.1.1 Adjustment with weight

According to the basic physical weighing principle at the installation site, each scale must be adjusted to the conditions on site such as gravity acceleration, temperature, location, etc.

- Ensure that no load is on the scales.
- Switch on the scales using the key “ON/OFF_TARE”.
- Press the key <ENTER> while the scales count down.
 - The following message appears in the display:

A rectangular digital display showing the text 'CON 1' in a segmented font. The 'C' and 'O' are connected, and the 'N' is separate. There is a space between 'CON' and '1'.

- Press the key <LEFT>.
 - The following message appears in the display:

A rectangular digital display showing the text 'Code' in a segmented font. The 'C' and 'o' are connected, and the 'd' and 'E' are separate.

- Press the key <ENTER>.
 - The message “- - - -” appears on the display.
- Enter the code “0000” using the keys <UP> and <LEFT>.
 - The <UP> key is used to change a value.
 - The <LEFT> key is used to change between the individual numbers.
- Confirm the code using the key <ENTER>.
 - The message (setting) appears on the display:

A rectangular digital display showing the text 'SET 179' in a segmented font. The 'S' and 'E' are connected, and the 'T' is separate. There is a space between 'SET' and '179'.

- Press the key <UP>.

- The message (CAL/calibration) appears on the display:



- Press the key < ENTER>.
 - The message (SPAN/two-point calibration) appears on the display:



- Press the key < ENTER>.
 - The message (Raw/raw measured value) appears on the display:



- Press the key < ENTER>.
 - The current raw measured value of the A/D converter appears on the display:



- Press the key <ENTER> or <ESC>.
 - The message (Raw/raw measured value) appears again on the display:



- Press the key <UP>.
 - The message (Zero) appears on the display:



- Press the key < ENTER>.

- The current raw measured value of the A/D converter appears on the display.

Example 

- Ensure that not load is on the scales.
- Briefly wait (until the displayed value hardly changes) and then confirm the value with the key <ENTER>.
 - The message “donE” briefly appears on the display.
 - The message (Zero) appears again on the display:



- Press the key <UP>.
 - The message (Load/load weight) appears again on the display:



- Press the key < ENTER>.
 - The currently set value of the load appears flashing on the display.
- Enter a value for the load using the keys <UP> and <LEFT> :

Example 

- Confirm the value using the key <ENTER>.
 - The current raw measured value of the A/D converter appears on the display.

Example 

- Ensure that the set load is on the scales.
- Press the key < ENTER>.

- The message “donE” briefly appears on the display.
- The message (Load/load weight) appears again on the display:



- Press the key <ESC> repeatedly to leave the menu.
 - The message (Save ?) appears on the display:



- Press the key <ENTER>, if the value is to be saved.
 - The messages “donE” and “off” briefly appear on the display.
 - The scales is switched off.
- Press the key <ESC>, if the value is not to be saved.
 - The message “off” briefly appears on the display.
 - The scales is switched off.

5.1.2 Theoretical adjustment

- Switch on the scales using the key “ON/OFF_TARE”.
- Press the key <ENTER> while the scales count down.
 - The following message appears in the display:

A rectangular digital display showing the text 'CON 1' in a seven-segment font. The 'O' is formed by two horizontal bars and a vertical bar on the right.

- Press the key <LEFT>.
- The following message appears in the display:

A rectangular digital display showing the text 'Code' in a seven-segment font. The 'o' is formed by two horizontal bars and a vertical bar on the right.

- Press the key <ENTER>.
 - The message “- - - -” appears on the display.
- Enter the code “0000” using the keys <UP> and <LEFT>.
- Confirm the code using the key <ENTER>.
 - The message (setting) appears on the display:

A rectangular digital display showing the text 'SET 119' in a seven-segment font. The 'O' is formed by two horizontal bars and a vertical bar on the right.

- Press the key <UP>.
 - The message (CAL/calibration) appears on the display:

A rectangular digital display showing the text 'CAL' in a seven-segment font. The 'O' is formed by two horizontal bars and a vertical bar on the right.

- Press the key <ENTER>.
 - The message (SPAN/two-point calibration) appears on the display:

A rectangular digital display showing the text 'SPAN' in a seven-segment font. The 'O' is formed by two horizontal bars and a vertical bar on the right.

- Press the key <UP>.

- The message (theoretical calibration) appears on the display:



- Press the key < ENTER >.
 - The message (field calibration/calibration with known weighing cells) appears on the display:



- Press the key < ENTER >.
 - The message (sensitivity) appears on the display:

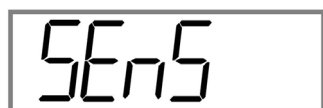

- Press the key < ENTER >.
- Enter a value using the keys < UP > and < LEFT > for the weighing cell sensitivity.



- Press the key < ENTER >.
 - The message "donE" and the following message briefly appear on the display again:



- Press the key < UP >.
 - The message (maximum load) appears on the display:



- Press the key < ENTER >.

- Enter a value using the keys <UP> and <LEFT> for the maximum capacity of the weighing cell.

Example 

- Press the key <ENTER>.
 - The message "donE" and the following message briefly appear on the display again:



- Press the key <UP>.
 - The message (Zero) appears on the display:



If necessary, a new zero point of the scales can be adjusted here.

- Press the key <ENTER>.
 - The current raw measured value of the A/D converter appears on the display:

Example 

- Press the key <ENTER>.
 - The message "Wait" (Wait) briefly appears on the display and the message (Zero) again:



- Press the key <ESC> twice to leave the menu.
 - The message (gravity/gravity factor) appears on the display:



If necessary, the gravity factor (gravity acceleration) can be adapted here.

- Press the key < ENTER>.
 - The value for gravity acceleration appears on the display.



- Enter the value for the gravity acceleration of the respective installation location here.
- Press the key < ENTER>.
 - The message “donE” and the following message briefly appear on the display again:



- Press the key <UP>.
 - The message (calibration method) appears on the display:



- Press the key < ENTER>.
 - The calibration method (field) activated last appears on the display:



- Press the key <UP>.
 - The message (Factory) appears on the display:



- Press the key <UP>.

- The message (SPAN) appears on the display:

A digital display showing the word "SPAN" in a stylized, blocky font. The display is enclosed in a rectangular border.

- Actuate the key <ENTER> to activate the desired calibration method.
 - The message "donE" briefly appears on the display.
 - The message (calibration method) appears again on the display:

A digital display showing the word "CALSEL" in a stylized, blocky font. The display is enclosed in a rectangular border.

- Press the key <ESC> repeatedly to leave the menu.

5.1.3 Adjustment correction

If the displayed value of the theoretical adjustment (factory-set default value) deviates from the value of the real weight, this value can be corrected.

- Simultaneously actuate the keys <UP> and <LEFT> for approx. three seconds.
 - The RH digit of the displayed weight starts flashing.
- Correct the value using the keys <UP> and <LEFT>.
 - The <UP> key is used to change a value.
 - The <LEFT> key is used to change between the individual numbers.
- Confirm the value using the key <ENTER>.
 - The message "donE" briefly appears on the display.

This correction can be repeated as often as required.

5.1.4 Reset to factory-settings

- Switch on the scales using the key "ON/OFF_TARE".
- Press the key <ENTER> while the scales count down.
 - The following message appears in the display:

A digital display showing the word "CON" followed by a space and the number "1". The display is enclosed in a rectangular border.

- Press the key <LEFT>.

- The following message appears in the display:



- Press the key <ENTER>.
 - The message “- - - -” appears on the display.
- Enter the code “0000” using the keys <UP> and <LEFT>.
 - The <UP> key is used to change a value.
 - The <LEFT> key is used to change between the individual numbers.
- Confirm the code using the key <ENTER>.
 - The message (setting) appears on the display:



- Press the key <UP> four times.
 - The message (reset) appears on the display:



- Press the key <ENTER>.
- Use the <UP> key to navigate.
 - The messages “ON” or “OFF” appear on the display.
- Actuate the “ON” message using the <ENTER> key.
 - The display is reset to factory-settings.

**Attention**

When the system is reset to factory-settings all settings made after delivery will be lost!

5.1.5 Setting the time and date

The scales is equipped with an internal clock.

- Switch on the scales using the key “ON/OFF_TARE”.
- Press the key <ENTER> while the scales count down.
 - The following message appears in the display:



- Press the key <UP> three times.
 - The message (Time) appears on the display:



- Press the key <ENTER>.
 - The message (hour) appears on the display:



- Press the key <ENTER>.
 - The value currently set appears on the display and starts flashing.
- Correct the hours using the keys <UP> and <LEFT>.
 - The <UP> key is used to change a value.
 - The <LEFT> key is used to change between the individual numbers.
- Confirm the value using the key <ENTER>.
 - The display automatically changes over to the input of the “Min.” value.
- Correct the minutes using the keys <UP> and <LEFT>.
- Confirm the value using the key <ENTER>.
 - The display automatically changes over to the input of the “Sec.” value.
- Correct the seconds using the keys <UP> and <LEFT>.
- Confirm the value using the key <ENTER>.
 - The display automatically changes over to the input of the “Day” value.

- Correct the days using the keys <UP> and <LEFT>.
- Confirm the value using the key <ENTER>.
 - The display automatically changes over to the input of the “Month” value.
- Correct the months using the keys <UP> and <LEFT>.
- Confirm the value using the key <ENTER>.
 - The display automatically changes over to the input of the “Year” value.
- Correct the year using the keys <UP> and <LEFT>.
- Confirm the value using the key <ENTER>.
 - The message “donE” briefly appears on the display.
 - The message (Time) appears again on the display:



- Press the key <ESC>.
 - The message (Save ?) appears on the display:



- Press the key <ENTER>, if the value is to be saved.
 - The messages “donE” and “off” briefly appear on the display.
 - The scales is switched off.
- Press the key <ESC>, if the value is not saved.
 - The message “off” briefly appears on the display.
 - The scales is switched off.

5.2 Quick selection menu

5.2.1 Setting the background lighting

- Ensure that no load is on the scales.
- Switch on the scales using the key “ON/OFF_TARE”.
- Press the key <LEFT> for two seconds.
 - The message (High-Low-Go-Mode) appears on the display:



- Press the key <UP> five times.
 - The message (Display) appears on the display:



- Press the key <ENTER>.
 - The message (Background lighting) appears on the display:



- Press the key <ENTER>.
- Use the <UP> key to navigate.
 - The message (Background lighting: Automatic/On/Off) appears on the display:



- Press the key <ENTER> when “bL AU” is displayed.

- The time (seconds) for background lighting can be entered here.
- The message (Background lighting) appears on the display:



- Press the key <UP> several times.
 - The displayed value is changed (10 - 120). The time value "120" displays the seconds, for which the display (inactivity of weight) remains active.
- Press <ENTER>.
 - The message "donE" briefly appears on the display.
 - The following message appears again in the display:



- Press the key < ENTER>.
- Use the <UP> key to navigate.
 - Following messages appear on the display:

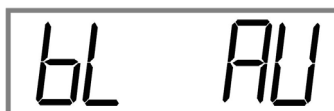

- Press the key <ENTER> when "bL On" is displayed.
 - The background lighting is always ON.
- Press the key <ENTER> when "bL Off" is displayed.
 - The background lighting is always OFF.
 - The message "donE" briefly appears on the display.

- The following message appears again in the display:



- Press the key <ESC> repeatedly to leave the menu.

6 Troubleshooting

6.1 In the event of a malfunction

We recommend switching off the scales briefly and disconnecting it from the mains, if a malfunction occurs in the program sequence. Then restart the weighing process.

6.2 Error messages of the scales

Error message	Description	Possible cause
E.016	No USB stick connected.	No USB stick available.
E.040	No data for transmission available.	No values saved in the long-term memory.
--OL--	Overload	The maximum set weighing range is exceeded.
Err.Lin	Error Limit Hi and LOW values incorrectly defined.	The set HI value is smaller than the set LOW value.
ErrScL	After switching on and the display self test no digitalisation unit is detected. The scales do not switch to weighing mode.	The scale is not connected.
Er2Ero	The weight is not added to the sum memory during weighing.	The scale is not zeroed prior to the weighing process →0← .

If any other malfunctions or error messages occur, please switch off the scale and after a short while on again.

If error messages occur again, please contact the Bosche customer service.

6.3 Customer service contact data

Bosche GmbH & Co. KG
 Reselager Rieden 3
 D-49401 Damme

Phone +49 5491 999 689 0
 Fax +49 5491 999 689 9
 Email info@bosche.eu

6.4 Information for the contact to the customer service

Owner/user	Specifications
Name of your company	
Name of a contact person	
Contact data Telephone Fax Email	

Tabelle 6.1: Your company

Product	Specifications
Model name	
Serial number	
Type key	
Date of purchase	
Name and location of the supplier	

**Note**

Fill in the table shown above when the display is delivered to be able to use all information without any problems at any time.

Information about the problem:

Examples for required specifications to support troubleshooting:

- Does the display operate fault-free since its delivery?
- Has the display any contact to water?
- Was there any damage due to a fire?
- Was there a thunderstorm before / during the malfunction?

**Note**

Please inform us about the entire history of the display.

7 Technical data

7.1 Type plate for a mobile display

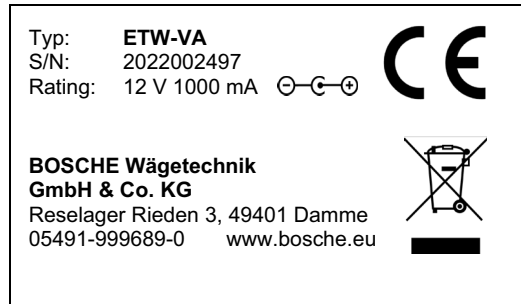

7.2 Technical drawing

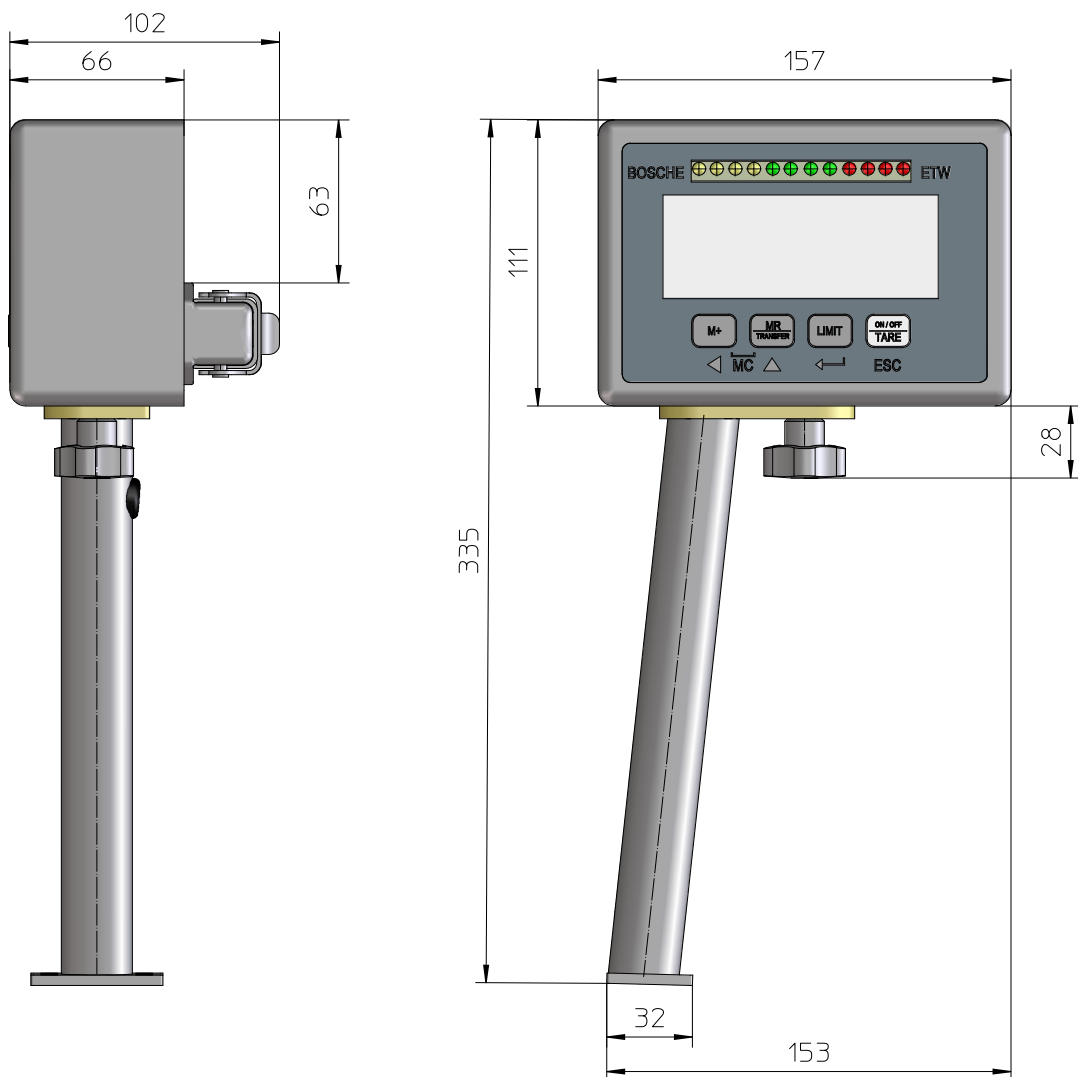

7.3 Technical data

Feature	Value / Unit
Type	Lithium-ion battery
Dimensions (W x H x D)	157 x 335 x 102 mm
Weight Aluminium housing	Approx. 1.35 kg
Power supply (external)	12 VDC / 230 VAC, 1000 mA via external mains adapter
Service life of rechargeable battery	Approx. 30 hours, depending on usage
Charging time of rechargeable battery	Approx. 3-5 hours
Adjustment	Automatic, external
Max. resolution (depending on the weighing cells used)	External 1/30,000 Internal 1/1,000,000
Display	6 digits, LCD illuminated, Digit height 30 mm
Keyboard	4 pressure point keys
Interface(s) (2 as an option)	RS232 optional: RS485, Lan, Bluetooth
Functions	Weighing value display, sum memory, presetable weighing with alarm, control signal lights
Weighing cell sensitivity	1mV/V~3mV/V
Number of weighing cells	Up to 4 with 350 Ohm each
AD converter	24 bits, 1 channel
Zero input range	0mV~5mV
Signal input range	0mV~15mV
Settling time	2 seconds typical
Operating temperature	+5°C to +40°C
Relative air humidity	max. 80 %, non-condensing

7.4 Scope of delivery

Component	Note
Display / Weighing terminal	
Mains adapter	
Operating manual	
Table/wall holder	Not included for the version with stand

8 Menu overview

8.1 Navigation in the menu

- A menu or subroutine is left by pressing the key <ESC>.
- The <UP> key is used to navigate between the individual menu points and modify editable numbers.
- The key <LEFT> serves to move the input cursor to the left by one digit.

8.2 Function menu overview

Actuate the <ENTER> key (or <LIMIT>) after the display has been switched on and while the countdown on the display counts down.

Menu	Subroutine	Options	Function
COM1	Mode 1	ASK	Ask mode, bidirectional. For further details, refer to the communication protocol (available upon request). Do not use with connected printers.
		oFF	No data transmission occurs.
		Cont	Continuous data transmission. Do not use with connected printers.
		St 1	Automatic printout when the weight is stable. A zero crossing is required, i.e. the load must be removed from the scale.
		St 2	Automatic printout when the weight is stable. A zero crossing is not required.
		St C	Automatic printout when the weight is stable and storage in the sum memory. A zero crossing is required.

Menu	Subroutine	Options	Function
COM1	Mode 1	Pr 1 (not available with ETW)	Data transmission by pressing the "Print" key when the weight is stable. A zero crossing is required.
		Pr 2	Data transmission by pressing the "M+" key when the weight is stable, with storage in the sum memory. A zero crossing is required.
		Pr 3 (not available with ETW)	Data transmission by pressing the "Print" key when the weight is stable. A zero crossing is not required.
		Pr 4	Data transmission by pressing the "M+" key when the weight is stable, with storage in the sum memory. A zero crossing is not required.
	Outp	PC // Bosche data string Print 1// Print 2 // HPP-250 Print 3 // LP-50 Print 4 // HPP-250 for HLS lifting carriages Print 5 // HP083 Print 6 // LP-50 for HLS pallet truck Remote display „rntdSP“// external large display (RD50, RD100, RD150, RD195) Lights // external three-colour light (PC0, PCL, PCG, PCH) (Status lamp SL3)	Protocol setting (Printer type)
Baud 1	1200, 2400, 4800, 9600, 14400, 19200, 28800, 38400, 57600, 115200,	Data transmission speed (Baud rate)	

Menu	Subroutine	Options	Function
	Part 1	8n1 //8 Data bytes, No Parity, 1 Stop Bit 7E1 // 7 Data bytes, Even Parity, 1 Stop Bit 7O1 //7 Data bytes, Odd Parity, 1 Stop Bit	Parity settings (for data transmission)
	Ntw.Rst	Network reset No Yes	The WLAN settings can be reset.
COM 2	As COM 1	As COM 1	As COM 1
USB	Multpl	// Alibi data blocks: the data blocks of all days are written in one file during saving on the USB stick.	Setting of the saving method of measured data on the USB stick.
	Single	// Alibi data blocks: an individual file is created for each measuring day during saving on the USB stick.	
Time	Hour, Min, Sec, Day, Month, Year		Setting of time and date.
LEGAL	ALB.SW (Alibi Switch)	Alb.On Alb.Off	Saving weight data in the internal memory (sum memory or alibi memory).
	ALB.SHW (Alibi Show)	EDIT.AB (Edit Alibi Number) "000000" // 0 flashing --> Selection of the alibi entry.	Show alibi entry (show a specific weight value saved in the sum memory).
		GET.LST (Get Last Alibi Number) (Number of Entries)	"0" // the number of values saved in the sum memory.
	TAC (Tac counter)	"0" // Number of the executed calibration processes (or number of the storage processes in the menu protected by a password).	
CODE		"- - -" flashing --> CODE = 0000	Change-over to the "Menu protected by a password".

8.3 Menu protected by a password

- Activation of the main menu
- Navigation to “CODE”
- Enter CODE = 0000 using the keys <UP> and <LEFT> and confirm with <ENTER>

Menu	Subroutine	Options	Function
SETTING	DEC 1	0.0, 0.00, 0.000, 0.0000,	Setting of the desired number of digits after the decimal point.
	INC	1, 2, 5, 10, 20, 50, 100, 200	Increments for the displayed weight (resolution).
	CAP	“00.0000” flashing --> Enter the value using the keys <UP> and <LEFT>	Setting of the maximum capacity.
	OLP	On	“—OVL—” appears when the max. capacity is exceeded.
		Off	Output of the current weight, even if the max. capacity has been exceeded.
	ULP	On	“—UVL—” appears when the min. capacity is gone below.
		Off	Output of the current weight, even if the min. capacity has been gone below.
	RnIn	off / rng2 / rng3 / int2 / int3	Multi-range / Multi-range scales (is not used!).
PAir	on oFF	Display scale pairing	
FUnc	Units Weight unit selection.	SEL 0: no weight unit SEL 1: g (gram) SEL 2: kg (kilogram) SEL 3: t (ton) SEL 4: lb (pound)	

Menu	Subroutine	Options	Function
SETTING	SPEED	SMPLNG	6, 12, 25, 50, 100, 200 ADC sampling rate Sampling rate of the external ADC (Attention: The setting does usually not require any changes! Effect on the weight calculation!).
CAL	SPAN Two-point calibration (zero point, load point)	Raw "000000"	The current ADC value appears.
		Zero "00000" with <ENTER>	Set zero point
		Load "001000" with <UP> and <LEFT> "000000" set the load point with <ENTER>	Display / setting of load weight
	mV - V Theoretical calibration	FIELD	SENS "001000" flashing --> Enter the value using the keys <UP> and <LEFT>. Setting the sensitivity of the weighing cells used. 2.0000 MVV Wert der Zellen (Default: 1.7200 for V1.n; 2.0000 for V5.n)
			T.CAP flashing --> Enter the value with <UP> and <LEFT>. Setting the maximum load of the weighing cells used. (Default: 1496.0 for V1.n; 04535 for V5.n)
			Zero "001000" set the zero point with <ENTER>. The current ADC value appears.

Menu	Subroutine	Options	Function
CAL	mV - V Theoretical calibration	FACTORY (Factory-calibration)	SENS "001000" flashing --> Enter the value using the keys <UP> and <LEFT>. Setting the sensitivity.
			T.CAP flashing --> Enter the value with <UP> and <LEFT>. Setting the maximum load.
			Zero "001000" set the zero point with <ENTER>. The current ADC value appears.
			Load "000000" set the load point with <ENTER>. The current ADC value appears.
	GrAvtY	G.FieLd	Adaptation of the gravity factor to correct the weight value on the site of scales use. (Default: 9.8130) "981276" flashing --> Set the gravity value with <UP> and <LEFT>.
		G.FctrY	Adjustment of the gravi- tational factor to correct the weighing result at the location where the scale is used.
	CAL.SEL Selection of the active cali- bration method.	SPAN Calibration method = "Span"	Two-point calibration
		FIELD Calibration method = "Field"	Calibration with adjusted cell values.
		FACTRY Calibration method = "Factory"	Factory calibration

Menu	Subroutine	Options	Function
Zero - M	Au.ZERO (Auto Zero menu)	Off / 0.25d / 0.5d / 1d / 2d / 3d / 4d	Set the range for "Zero_Tracking". (Zero tracing function).
	Rn.ZERO (Zero Range)	0, 2, 4, 10, 20, 50, 100	Range, within which the zeroing function can always be carried out (referred in percent to the maximum admissible total weight of the scales).
	On.ZERO (On Zero)	0, 2, 4, 10, 20, 50, 100	Range, within which the zeroing function can be carried out when the scales is switched on (referred in percent to the maximum admissible total weight of the scales).
RESET	On OFF		Reset to factory-settings

8.4 Quick selection menu (HLG menu)

**Note**

The quick selection menu serves for a facilitated input or reading out parameters and for display parameterisation.

The quick selection menu can be used to set parameters for the function of control weighing cycles, for the alibi memory, the printer, the background lighting and automatic switch-off.

The quick selection menu (while the scales is in weighing mode) can be opened by pressing the key <LEFT> (or <SAVE>) for approx. two seconds.

Menu	Subroutine	Options	Function
HILOGO	HLG.MOD (High-Low-Go - Mode)	Off = three-colour light is deactivated 3-colour = 3-colour mode for the sorting lights 4-colour = 4-colour mode for the sorting lights	Settings for the sorting lights.
	BEEP	Off = acoustic signal deactivated Be OK = acoustic signal in the "Green area" Be Lo = acoustic signal in the "Yellow area" Be Hi = acoustic signal in the "Red area" Be HiLo = acoustic signal in the "Yellow area" and the "Red area" Be OVL = acoustic signal for overload or underload.	Additional acoustic function for the sorting lights (referred to the HLG mode = 3rd colour)
	STORE	On = The HLG limit values are saved. Off = HLG limit values must be set again after a power reset.	Saving the HLG limit values.
	BRIGHT (Brightness)	"BrI.000" flashing --> Enter the value using the keys <UP> and <LEFT>. Brightness 0 - 100 % (Default: 50%)	Settings for the brightness of the sorting light LEDs. The brightness is subdivided in 32 stages and a change is visible each 3-4 %.
MEMORY (Sum memory)	Clr.Alb (Clear Alibi Memory)	Clr.No = Do not delete the sum memory Clr.Yes = Delete the sum memory	Deleting the sum memory.

Menu	Subroutine	Options	Function
ALIBI	EDIT.AB (Edit Alibi Number)	“000000” flashing --> Enter the value using the keys <UP> and <LEFT>.	Display of a specific entry from the sum memory.
	GET.LST (Get Last Alibi Number)	“0” the number of values saved in the sum memory.	
PR1	Info	Number / Alibi / Date / Time / Gross / Net / Tare /T.Gross/ T.Net / T.Tare Confirm On or Off with <ENTER>.	Setting the individual elements for the print ticket (e.g. whether or not the consecutive number, the date, etc. are to be printed onto the print ticket). Confirm On or Off with <ENTER>.
	Copy	Value 0 - 4	Number of the print tickets to be printed.
FUNC	APPS (selection of the active application)	Weight = Standard weight measuring	
		Count = Count application	
		PER (Percentage) = Special HLG function (modulation of the sorting lights LEDs depending on only one limit value = 100%).	
		ANIMAL = special animal filtering function is used.	
		PEAK = Peak function is activated.	The menu protected by a password cannot be activated while the hold or peak functions are active.
	HOLD = Hold function is activated.		
WeiCor (Weight correction)	“000000” flashing --> Enter the value using the keys <UP> and <LEFT>.	Weight correction	

Menu	Subroutine	Options	Function
DISPL	b.Light (Backlight) Settings for the display	bL AU (Backlight Auto)	bL.10 / 20 / 30 / 40 / 50 / 60 / 70 / 80 / 90 / 100 / 110 / 120 --> Set the value with <UP> Automatic activation / switch-off of the background lighting after N seconds. The background lighting is automatically activated when the weight changes or a key is pressed.
		bL On = Background lighting always ON.	
		bL Off = Background lighting always OFF.	
	AU OFF	“AU 00” flashing --> Enter the time (minutes) using <UP> and <LEFT> and confirm with <ENTER>. 0 - 99 Value “00” = no switch-off	Automatic switch-off of the scales, if no key is actuated and the weight does not change.
	bright	bri.10 - bri.100 bri.OFF	Settings for the brightness.
LNG (Language)	ENG = “G” GEr = “B”	The symbol for gross appears as “G” or “B” on the display.	

8.5 Menu overview (graphical representation)

Quick selection menu

Navigate:

- Press the <ESC> key to exit a menu or submenu.
- Use the ▲ <UP> key to navigate between the menu items.
- Press the ◀ <LEFT> key to move the input cursor one position to the left.

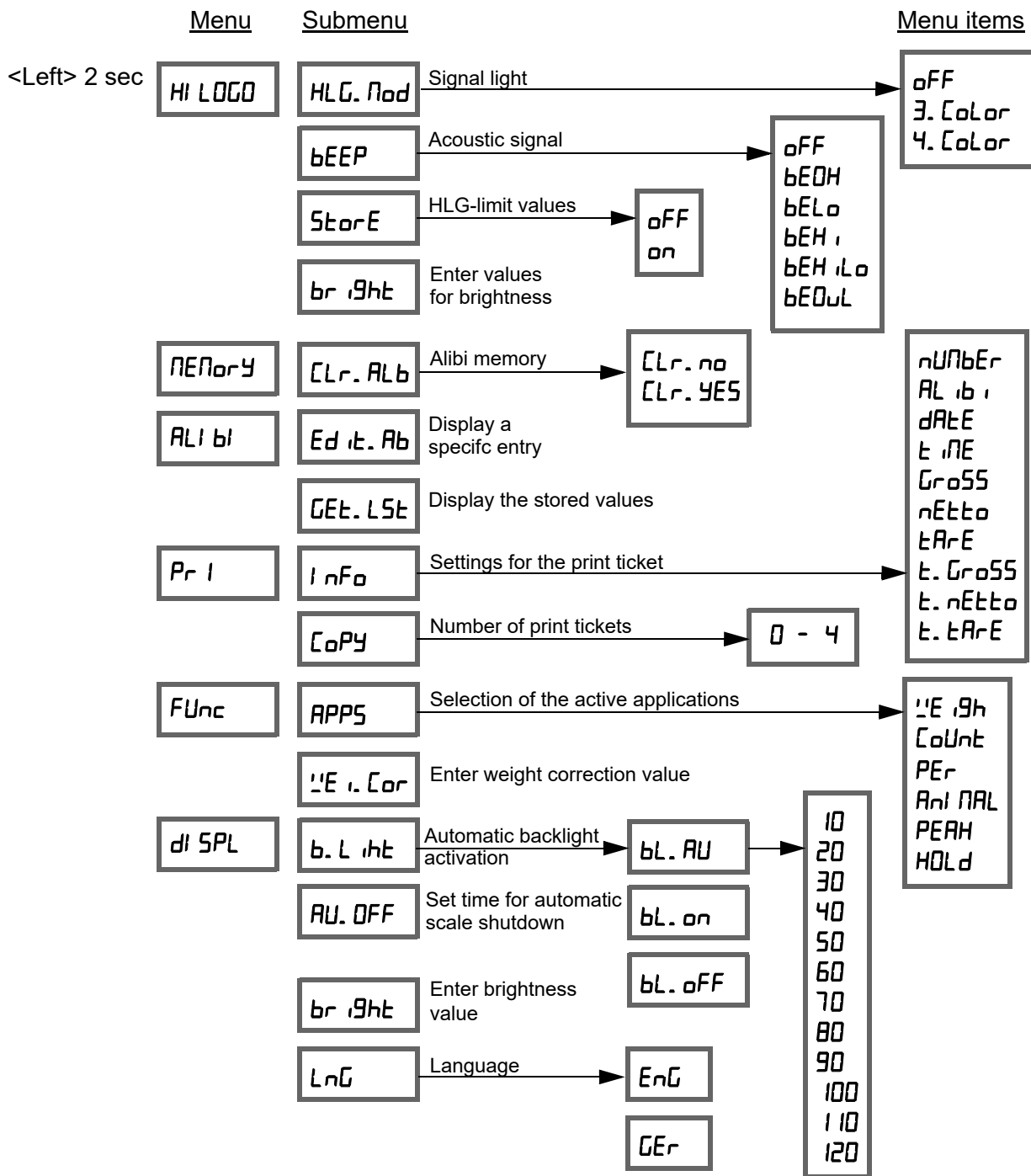

Quick selection menu

Navigate:

- Press the <ESC> key to exit a menu or submenu.
- Use the ▲ <UP> key to navigate between the menu items.
- Press the ◀ <LEFT> key to move the input cursor one position to the left.

Turn on the scale and press the <Enter> key during the countdown.

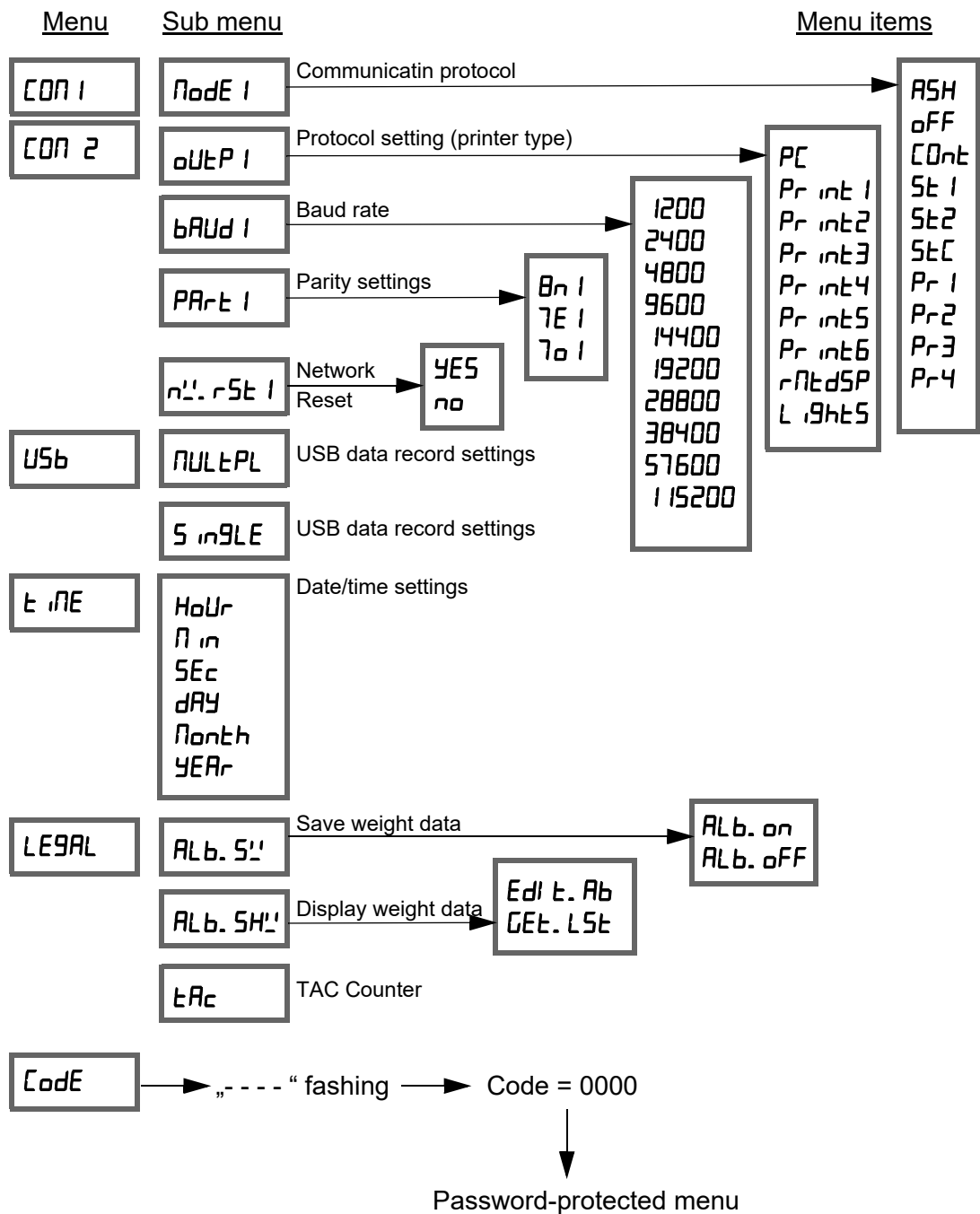

Password-protected menu

Navigate:

- Press the <ESC> key to exit a menu or submenu.
- Use the ▲ <UP> key to navigate between the menu items.
- Press the ◀ <LEFT> key to move the input cursor one position to the left.

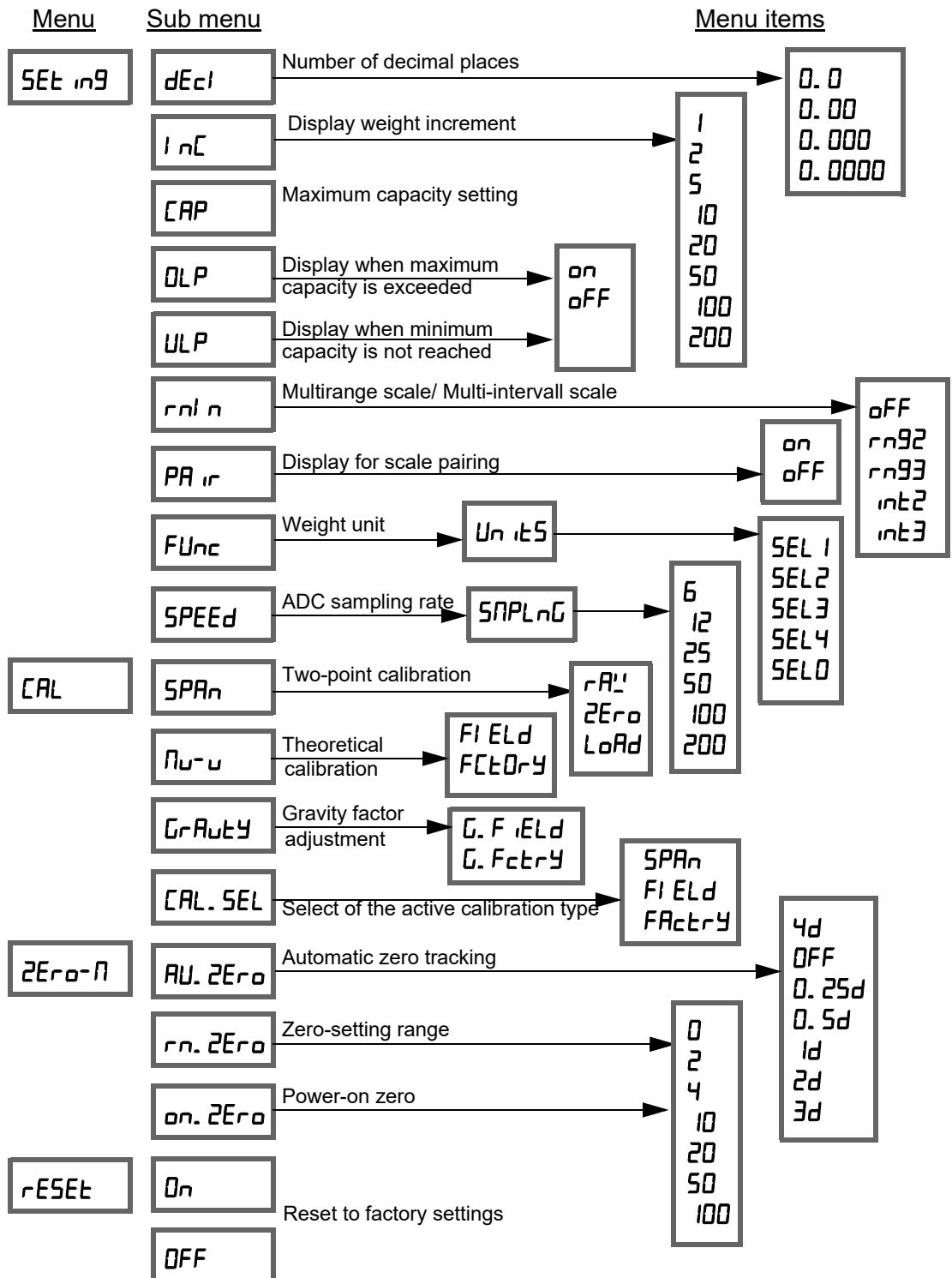

9 Declaration of Conformity

9.1 Declaration of Conformity for non-verified scales



Bosche GmbH & Co. KG
 Reselager Rieden 3
 D-49401 Damme
 Telefon: 0 54 91 / 999 689 - 0
 Telefax: 0 54 91 / 999 689 - 9
 E-Mail: info@bosche.eu
 Internet: www.bosche.eu

EU-Konformitätserklärung Declaration of conformity • Déclaration de conformité Conformiteitsverklaring • Declaración de conformidad	
Typ / Modell Type / Model • Modèle Model • Tipo / Modelo	Anzeige ETW für nicht selbsttätige, ungeeichte Waagen for non-automatic, non-verified scales pour balances non automatiques et non étalonnées voor niet-automatische, niet-gekalibreerde weegschalen para básculas no automáticas y sin calibrar
Seriennummer siehe Typenschild. For the serial number, see the nameplate. • Pour le numéro de série, voir la plaque signalétique. Voor het serienummer, zie het typeplaatje. • Para el número de serie, consulte la placa de identificación.	
Hersteller Manufacturer • Fabricant Fabrikant • Fabrikante	Bosche GmbH & Co. KG

Die alleinige Verantwortung für die Ausstellung trägt der Hersteller.

The sole responsibility for the issue carries the manufacturer. • La seule responsabilité de l'exposition porte le fabricant. • De verantwoordelijkheid voor de uitgifte draagt de fabrikant. • El único responsable de la publicación lleva el fabricante.

Der oben genannte Gegenstand der Erklärung erfüllt die einschlägigen Harmonisierungsrechtsvorschriften der Union:

The above-mentioned object of the declaration complies with the relevant harmonization legislation of the Union • L'objet de la déclaration susmentionné est conforme à la législation d'harmonisation pertinente de l'Union • Het bovengenoemde voorwerp van de verklaring voldoet aan de relevante harmonisatiewetgeving van de Unie • El objeto de la declaración mencionado anteriormente cumple con la legislación de armonización pertinente de la Unión

2014/35/EU Niederspannungsrichtlinie Low voltage Directive	EN 61010-1:2020 für / for / pour / voor / para 230/115 VAC
2014/30/EU EMV-Richtlinie EMC Directive	EN 55022:2011 EN 61000-6-2:2019 EN 61000-6-4:2019 EN 61000-4-2:2009 EN 61000-4-3:2011 EN 61000-4-4:2012 EN 61000-4-5:2014 EN 61000-4-6:2014
2011/65/EU RoHS	EN IEC 63000:2018

Unterzeichnet für und im Namen von Bosche:

Damme, 17.06.2022

Dipl. Ing. Jarmila Bosche, PhD.
Geschäftsführer • Managing Director
 Directeur général • Directeur • Director general